



## pipegrip

Schont das Material, den Greifer und Ihren Geldbeutel!

[www.um-ag.ch](http://www.um-ag.ch)



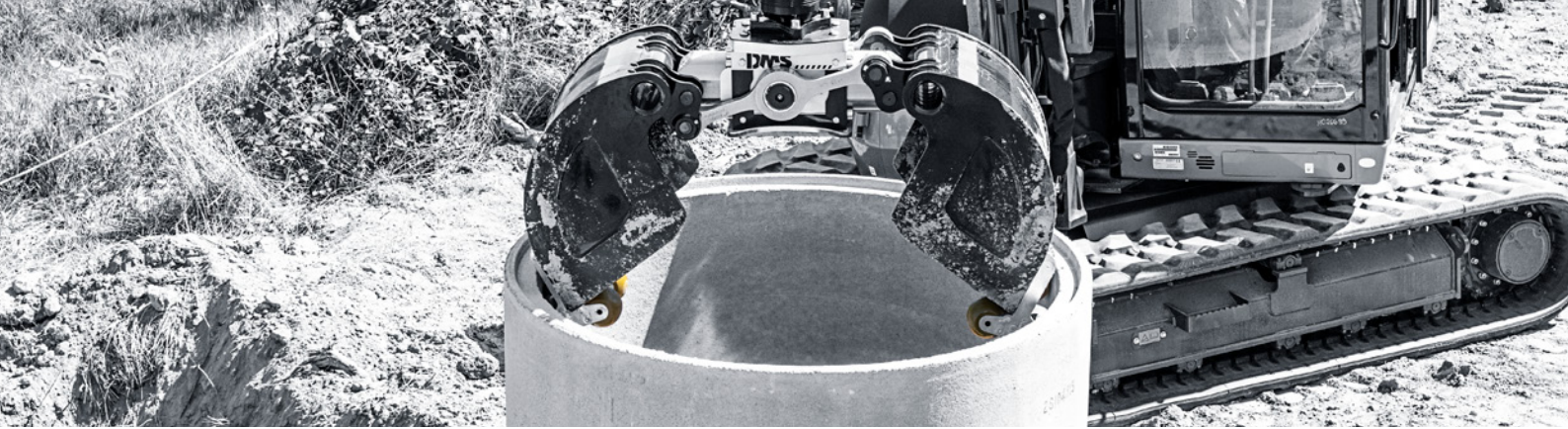

Der **pipegrip** kann in kürzester Zeit an einem DMS-Greifer montiert werden. Es lassen sich damit sowohl runde, als auch eckige Baumate-

rialien wie z.B. Rohre, Schachtringe, Steine, Beton Legosteine, Treppenstufen etc. problemlos und materialschonend positionieren.

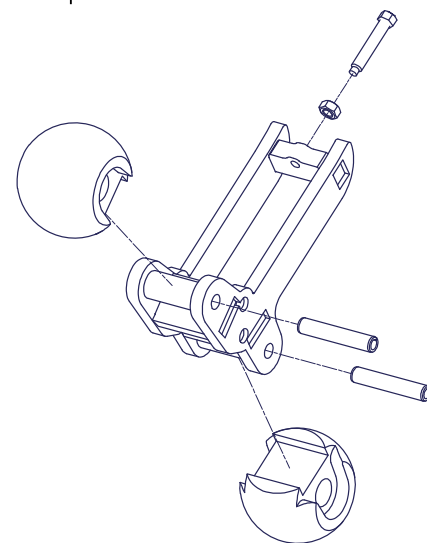
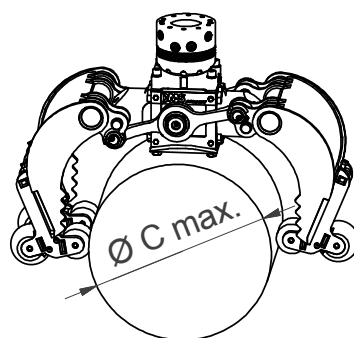
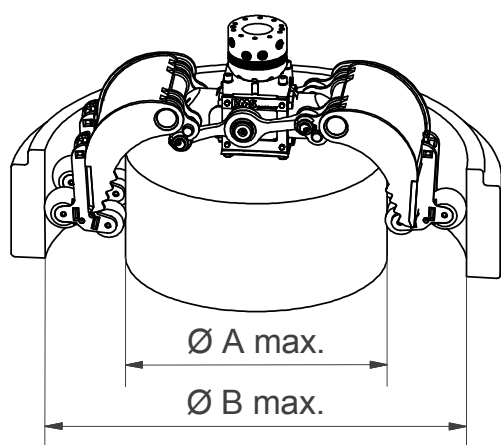

**Baggerdienstgewicht:**

	1-2t	2-3,5t	2-3,5t	3,5-6t	6-9t
A in mm:	610	770	990	990	1500
B in mm:	1060	1200	1470	1470	1980
C in mm:	420	540	680	680	1000
Anzahl:	3	3	3	3	4
Hebelast [kg]:	200	350	600	600	900



**Ullmann<sup>VG</sup> AG**

Breitstrasse 1  
CH-9595 Bussnang

Tel. +41 (0)71 626 57 47  
Fax +41 (7)71 626 57 48

[www.um-ag.ch](http://www.um-ag.ch)  
[umag@um-ag.ch](mailto:umag@um-ag.ch)